

## F350 / F360

## Installation manual



**F350 Classic**



**F360 Duro**

### Specifications

**Supply** 180-240Vac 50Hz  
**Speed** 110mm/sec  
**Duty cycle** 25% 20 times/hr  
**Temp'** -20°C to 40°C

	<b>F350</b>	<b>F360</b>
<b>Standby power</b>	<5W	<6W
<b>Door max</b>	<8m <sup>2</sup>	<11m <sup>2</sup>
<b>Motor power</b>	100W	150W
<b>Force</b>	700N	1100N

- **Description** 2
- **Preparation**
  - Contents 3
  - Rail assembly 3
- **Installation**
  - Header bracket 5
  - Door bracket 6
  - Lifting the rail 6
  - Rail brackets 7
  - Electrical 7
- **Programming**
  - Initial settings 8
  - Remotes 11
- **Commissioning**
  - Trouble shooting 12
  - Accessories 13
- **User notices**
  - Manual disconnect 14
  - Safe operation 14
  - Warranty 15

## Description

The F350 and F360 garage door openers are designed for horizontally tracked domestic garage doors. Fitting to other door types or in public areas is at the installer's discretion.

All openers meet European norms for safety as required by EU law. Refer to the certificate of conformity in this manual for list of standards in compliance.

Both models use the same gauge rail which is available in differing lengths, number of sections, and chain or belt drive.

Openers have a 24Vdc motor. An incremental encoder monitors door position. On commissioning the opener runs a door test to record minimum forces required. Doors cannot be moved while the opener is engaged. An override cord on the rail disengages the motor. Used in exceptional circumstances, eg power failure.

Remote controls vary between models. All Foresee remotes, wireless buttons, wireless keypads are compatible with any Foresee control panel. The opener can be set to respond to 1 of 4 channels. A home can have 4 automated doors and/or gates. Up to 15 remotes can be registered to an opener. A safety input is provided for optional safety photo beams or edges.

Openers are delivered in sets;

- FK351** "Classic" - 700N motor, 1 piece chain drive
- FP351** "Classic" - 700N motor, 1 piece belt drive
- FK352** "Classic" - 700N motor, 2 piece chain drive
  
- FK361** "Duro" - 1100N motor, 1 piece chain drive
- FP361** "Duro" - 1100N motor, 1 piece belt drive
- FK362** "Duro" - 1100N motor, 2 piece chain drive

## Door condition

Automated doors must be sound, well balanced, and in good working order. Guide rollers and tracks must be free running and well maintained. A door should be able to be lifted with one hand, and stay in the half way position un-supported. The door frame and ceiling mounting points must be sound to take the opener's weight and horizontal forces required to pull the door.

The rail length determines the door height. Max height for a 3m rail is 2.24m. Longer rails can be specified for up to 2.8m doors. Openers may be used on canopy doors with a convertor arm, but at the installers risk.

Doors without an alternative access door may need an external emergency door release in case of power failure. Remove all bolts from the door to prevent jamming while automated.

### User Safety warnings



Automatic doors can be hazardous. It is the responsibility of the home owner to be aware of the risks and provide, adequate warning of hazards. Users should be given instruction on the safe use of the automatic door. Do not let children or untrained people use remotes. Do not let unsupervised children near the door.

This manual is written for engineers aware of construction criteria for automatic doors and accident prevention criteria in force in the automation industry. Only qualified persons may do installation work on a door that could affect the door's risk assessment.

Turn off the power before working on the gate. We recommended signage to warn users and members of the public of risk of injury to pedestrians. Do not permit public access to the door area. Do not use remotes when out of sight of the door.

## Contents



The opener carton contains a motor head, the fixing pack above, two hangers, and a curved arm. Remotes and accessories depend on the set so check the carton label.



There are two sections. The chain is laid out through the sections. Stretch the sections out in a line to take out any tangles in the chain

## Assembling a 2 piece rail

A two piece rail pack may be ordered. to be assembled on site. Rails can be made up to 3m or 3.6m lengths. Follow the instructions below. One piece rails need no assembly.



Clear an area 3m long. Lay down some cloth or carboard to keep the chain clean. Cut off all the packaging.



Take out any cardboard packing. Snip any packing ties that hold the chain.

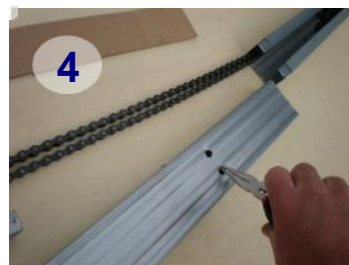

Turn over the centre rail section and turn up the four locking tabs.

Lay it down and align the rail sections letting the chain lay flat inside the rail.



Slide the locking sleeves across the rail ends. This is not easy. It best done on a flat surface. If continues to resist, check the ends of the rails for damage.



Check that the chain engages properly with both cog wheels. The chain should be long enough. Slacken off the spring if necessary



Tighten the chain checking for tension. The chain should move sideways, but not touch the top or bottom of the rail



When the sections are joined together, turn the rail over, then turn up all the remaining locking tabs.

Be careful not to let the chain fall out when it is upside down.



Place the motor head in its polystyrene box for protection while assembling.

Find the olive in the accessories bag. Fit it to the motor shaft first.



Turn the rail over (chain down) and fit the rail over the motor shaft and olive. It will need a bit of patience to align it. Fit two saddle clamps with the four self tappers.



The roof hangers may also be fitted to the rail and motor head if you know the roof joist positions. Apply a finger of grease to the chain.

## Header bracket

The header bracket is fixed to the door frame in the centre of the opening. It must be set high enough for the door not to interfere with the rail throughout the door's travel.

Bracket height depends on the door thickness and door roller design. Open the door to see the highest point the door edge reaches.

Mark hole centres, then mount the bracket with four suitable fixings.

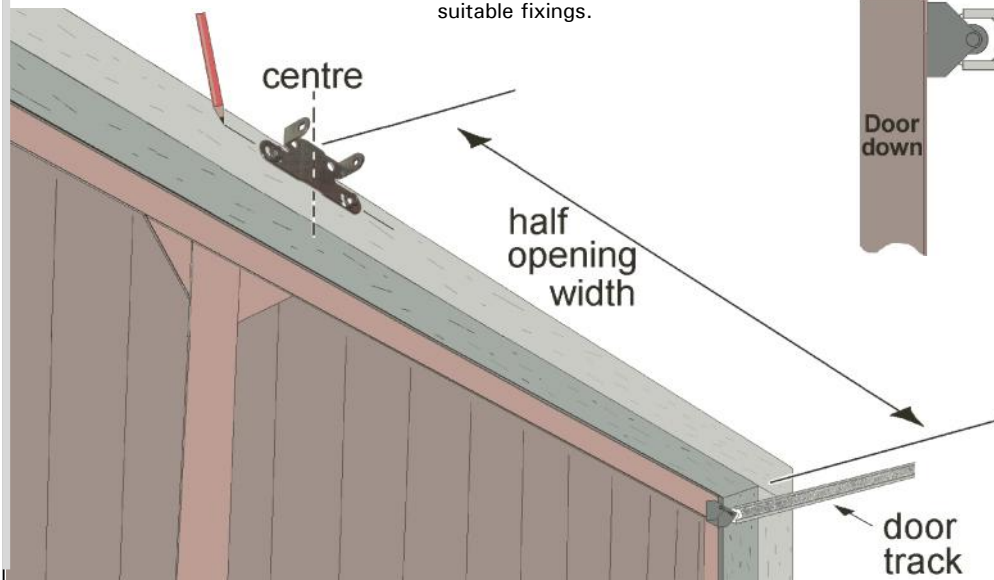

The header bracket's lower slotted mounting holes must be at least 10mm above the highest point the door reaches. The slotted holes can be set 200mm higher if you prefer, but over 50mm from the ceiling.

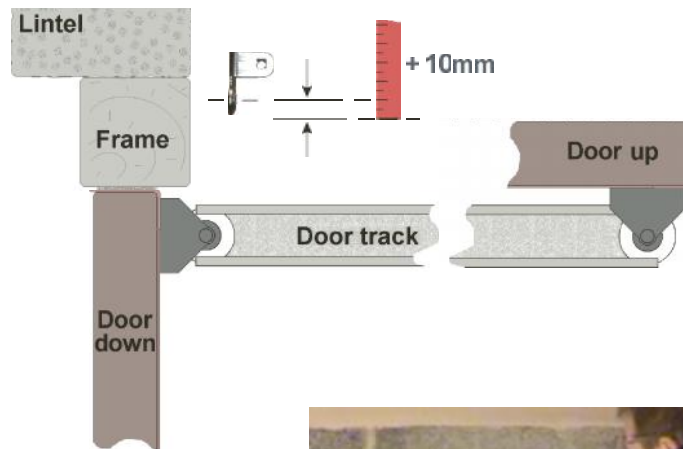

## Door bracket

The door bracket fixes to the centre of the door below the header bracket. It requires a strong fixing, so choose a structural member of the door.

Height is not critical, but should be within 150mm of the top of the door.

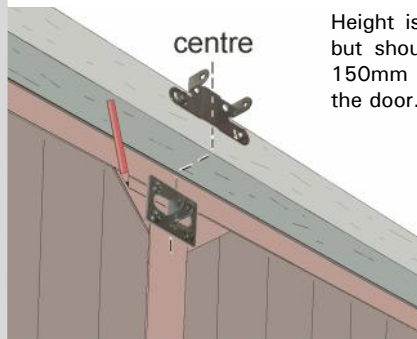

The full force of the opener will be pulling on this bracket. Bolting through the door is best, with the nuts on the inside. Coach bolts have plain heads that cannot be tampered with from outside.

Find the 8mm cotter pin, its split pin, and the 'J' bar.

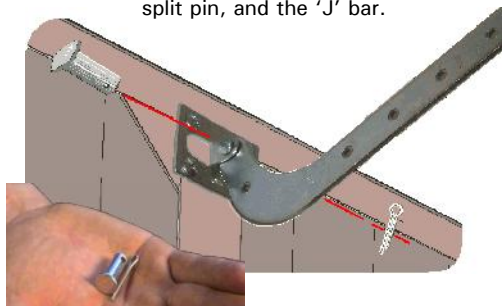

Fit the 'J' bar to the door bracket with the cotter pin. Insert the split pin. Open one leg to secure it.

## Lifting the rail

You will need a step ladder. Lean the opener against the door frame with the motor resting on polystyrene packaging for protection.

Fix the rail end to the header bracket with the long bolt. Insert the bolt thru the bracket's square hole first. Fix the roof hangers to the opener head.

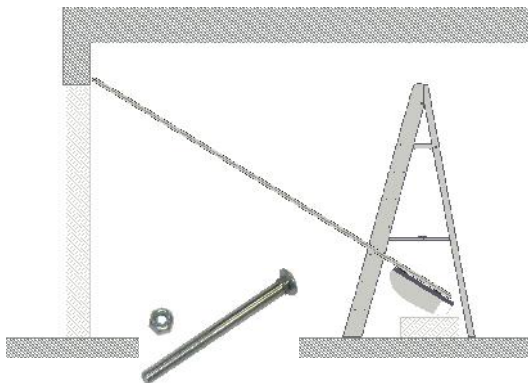

Lift the head onto the steps until the rail is horizontal. Ensure the opener's rail is parallel with the door guides.

Run the door up & down. Check it clears the opener. Bend the two roof hangers ready to fix to the ceiling.



Rail brackets

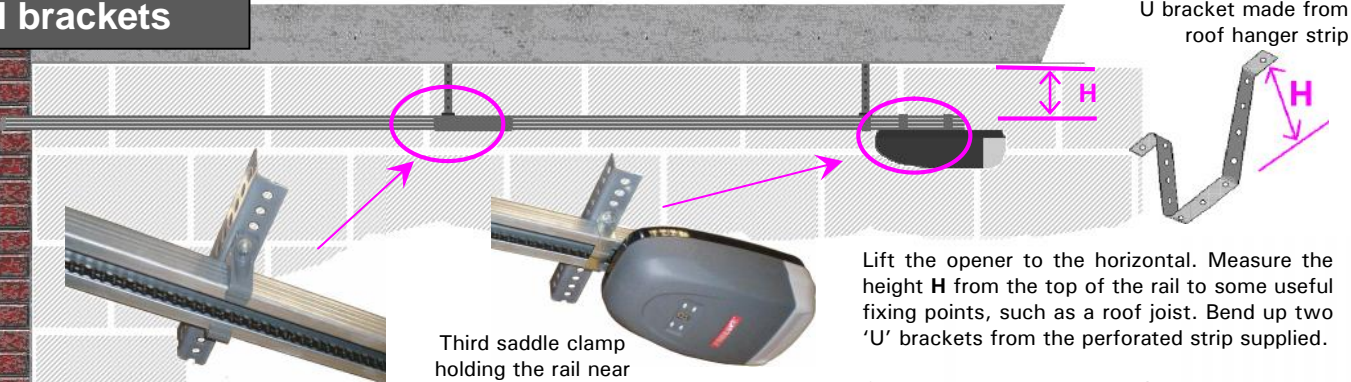

Two plastic rail clamps holding the rail at a mid position.

Check the rail is perfectly level and secure. Brackets may need slight bending. The chain may scrape inside the rail if it is not true.

Third saddle clamp holding the rail near the motor head



Lift the opener to the horizontal. Measure the height **H** from the top of the rail to some useful fixing points, such as a roof joist. Bend up two 'U' brackets from the perforated strip supplied.

Open the garage door and align the motor head laterally. Mark the ceiling. Lower the opener, then fix the bracket to your ceiling marks. Fix the third saddle clamp to the rail near to the motor head, then bolt it to the hanging 'U' bracket, or a piece of angle.

Fix the second 'U' bracket half way along the rail. This time you must use the two plastic rail clamps because the J bracket passes this point

Run the door up and down to make sure it clears the rail and brackets. Then connect the 'J' bracket to the rail carriage.



Electrical

The opener is pre-wired with a UK plug. On power up, the courtesy light will come on and the motor will beep. The display will then show a circulating pattern of LEDs.



1. Set open position
2. Set closed position
3. Force learning
4. Force setting
5. Remote channel
6. Alarm setting
7. Auto-closing
8. Service alarm

<b>Mandatory</b>	
Default = 4	
Default = 2	
Default = OFF	
Default = OFF	
Default = OFF	
Default = OFF	

Programming teaches the opener about a door. The opener will not function until the first three programming steps are complete. The next five steps have default settings that are typical of most installations. Remotes are supplied pre-programmed to the opener.

Programmed via the 4 buttons "S", "P", "+" and "-". Key "S" stores remotes. Key "P" is an enter button. The display shows the programme step number. The "+" and "-" keys are used to set the parameter. On power up the lamp comes on, there's a beep, then display shows a circulating pattern.

A flashing display means the parameter is waiting to be set, or the motor is still running. Programming must be finalised in correctly, or settings will not be saved.



To start, press and hold "P" for 5 seconds. The display shows step 1.



## Step 1 – set open position

First step sets the "door open" position. Take care, it is the first time a motor has lifted the door.

The open position is not critical. It is not necessary to set the door to the very furthest position.

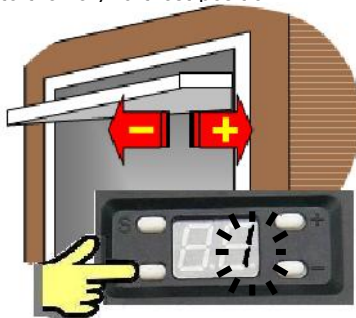

Use + and - to select step "1" then press "P".



The "1" begins to flash.

Use + and - buttons to set the "door open" position. The door closes with the - button and opens with the + button

Press "P" to save the open setting.

## Step 2 – set close position

Do not set the "door closed" position too tight or the door frame will be seen as an obstacle. Set closed point 10mm before the door touches the frame.

You can switch between the open and close settings but press "P" each time.

Use + and - to set the "door closed" position. The door closes with the - button and opens with the + button

Use + and - to select step "2" then press "P".



The "2" begins to flash.

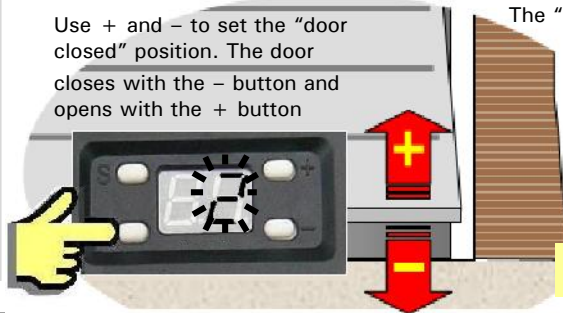

Press "P" to save the close setting.



Step 3 – force learning

The opener runs a cycle measuring the force required at each stage. Close the door. Use + – keys to select step 3.



Press "P" to start the test. The 3 flashes as the door opens. When it has stopped, press "P" to save the force settings.



Press "P" to run a closing test. When the door is closed fully, press "P" to save.

Step 4 – photobeam enable

Enables a photobeam. Skip this step if not fitted. The default setting is off.

Select step "4" then press "P"

Press "+" key to enable (beeps once), or "-" key to disable (beeps twice).

Press "P" to save the new setting.

Step 5 – photobeam test

Used to test the photobeam. Skip this step if a photobeam is not fitted. Select step "5" then press "P"



The display shows a flashing "5" and the door rises. Block the beam. "A" should be displayed. If not, check wiring.

Press "P" to exit the test

Step 7 – alarm enable

This door "left open" alarm sounds after the door is open for 10 mins. Default is off.

Select step "7" then press "P"



Press "+" key to enable (displays 1). Press "-" key to disable (displays 0).

Press "P" to save the new setting.

Step 6 – force setting

Force setting selects the level of additional force permitted above minimum force learned in step 3.

There are 6 settings, displayed as patterns on the display. Examples are shown below. Setting 4 is the default force, setting 6 is the strongest force.



Use + and – keys to select step 6 then press "P" to display the force setting character. Adjust with + and – keys. Press "P" to save.

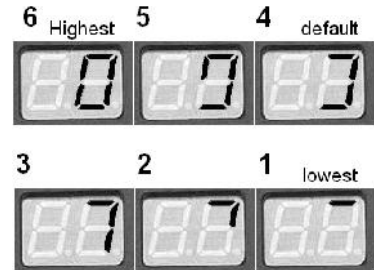

## Step 8 – remote channel

By default the door opens on channel 2. For double garages, it is normal to set the second opener to channel 1. There are 4 channel options. To change channel, use + and - to select step "8" then press "P"



The display shows a flashing channel number (from 1 to 4). Use the + and - buttons to select a channel number.

Press "P" to save the new channel.

## Step 9 – auto close time

The opener can be programmed to close after a time delay. There are nine delays from 30 secs to 240 secs. Setting zero disables the autoclose function.

The opener beeps and the light flashes for 20 seconds before the door starts to close. Opener beeps while it is closing.

When setting autoclose, you need to be confident a car can pull in clear of the door every time. We recommend fitting the optional photobeam which prevents the door closing until doorway is clear.

Select step "7" - press "P". Displays autoclose setting character 0 to 9.



Use + and - keys to select a delay as required, then press "P" to save.

Zero means the auto-close is off.



- 1 for 30 secs
- 2 for 60 secs
- 3 for 90 secs
- 4 for 120 secs
- 5 for 150 secs
- 6 for 180 secs
- 7 for 210 secs
- 8 for 240 secs

## Step A – lamp function

When two openers work on one remote, step A enables both lamps can come on when either door is opened. Default setting is off. Select step "A" with + & -, then press "P"



The display shows a "0" for one lamp, or "1" for both. Use the + and - buttons to select.

Press "P" to save the new setting.

## Step B – alarm setting

Sets a service alarm to sound after 2000 cycles. Reset on power down. The default setting is off. Select step "b" then press "P"



The display shows a "0" for disabled, or "1" for enabled. Use + and - buttons to select.

Press "P" to save the new setting.

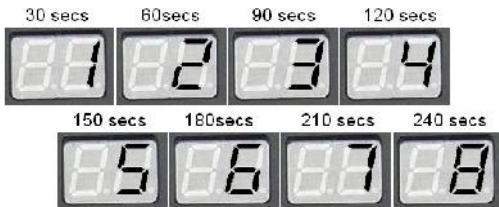

## Step 9 – finalise programming

Programming must be finalised correctly to save any changes you have made. Finalising can be performed any time after completing the force setting procedure step 3.

Use + key to return to step "1".



Hold down "P" key for 5 secs, or until display shows "0".

Hold down "P" key for 5 secs, or until display shows "0".



The opener is now ready to use.

## SHORTCUT

To finalise after completing step 3 (force setting) you do not need to return to step "1". Just hold "P" down for 5 secs.



## Add remotes

Remotes supplied with openers are already set in memory. Openers can store up to 15 remotes. To add a new remote, press "S" for 1 sec. The point LED will light.



Press either button twice to add. More remotes can be added while the point is still on.

## Delete remotes

Remotes cannot be removed individually. To delete one remote, the whole memory must be cleared. Good remotes can be re-entered.



Press 'S' for 8 secs. The 0 will appear on the left. Holding 'S' for 5 secs more until the 0 disappears. The memory is clear.

## Channel setting

For two garage doors, set left door to channel 2, set right to channel 1. Whichever channel is pressed, both courtesy lights will turn on because the remote was saved onto both openers.

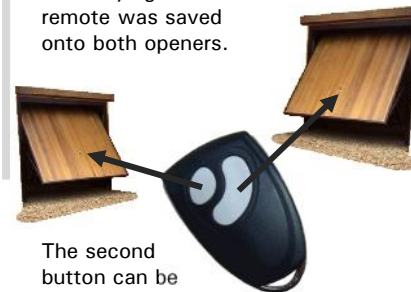

The second button can be used for a gate. Four channel remotes will work 4 devices. Each button is dedicated to a channel.

## Troubleshooting

The trouble shooting table is a summary of the most common issues encountered.

### DISPLAY CODES

- L** Limit reached (this is normal)
- F** force map has been exceeded
- H** is an encoder reading failure
- A** indicates the photo beam is blocked

### FIRST CHECK

Check the power is on and the disconnect is engaged. Try another remote. Check the rail is correctly tensioned and that the door is properly balanced and free running.

### ON POWER UP check that

- The courtesy light comes on
  - The motor beeps once
  - Display shows the circular pattern
- If any of these fail, check all the fuses.

	Symptom	Points to check	Remedies to try
<b>1</b>	Remote will not programme in.	Is remote LED on? Is it the right remote type? Is the memory full? Is the program light on?	The remote might be faulty. Opener problem likely. Did you complete the "finalise programming" step?
<b>2</b>	Scraping noise from the rail. Chain or belt is rubbing or jamming. The motor can be heard straining.	Rail not flat along its length, or chain too slack. Is the chain worn or broken? Check the chain is wrapped around the middle of the end cog wheel.	Adjust rail centre support. Re-tension chain or belt. Remove the motor head. Re-seat the chain on its pulley. Check the offset ring is fitted properly.
<b>3</b>	Courtesy light comes on but door doesn't move.	If you can hear the motor running, perhaps the release cord has been pulled. Is the chain in the middle of the cog at the motor end.	You may be pressing the wrong button. The disconnect is not engaged. The chain is broken.
<b>4</b>	The door opens as soon as the power is turned on.	Has the client lost a remote? Could it be under a book or object resting on the button?	If there is an exit button, disconnect it. Is the FR11's LED on all the time?
<b>5</b>	The door does not open after any command	Check power to opener. Door bolts not released? Door is blocked from outside? Check the remote.	Check the supply socket with a lamp or power tool. Clear any obstructions. Use another remote. Motor should beep each time it gets a remote command.
<b>6</b>	The door almost fully closes, then immediately opens again	Check the floor beneath the door is clear. Try helping the door down from inside the garage.	Opener interprets the door frame as an obstacle. Run through the close limit programming again.
<b>7</b>	The door gets half way down, then stops and re-opens.	Pull the release cord. Run the door manually. Is it well balanced? Check the door springs & cables. Inspect the door rollers. They must not be loose.	Balance the door properly, then run through the programming limits and force mapping. Doors will skew if the springs are uneven or rollers are loose.
<b>8</b>	An 'L' appears on the display		This is normal. The door has reached its limit.
<b>9</b>	The motor runs and the chain or belt moves, but the door doesn't move.	Try moving the door manually. If it is jammed, then clear the jam first. See fault reference 7.	If the door moves, the release has not re-engaged. The door running gear may need a good servicing.
<b>10</b>	The door does not stop where it is set.	Check fault reference 6.	Re-do limit programming. Make sure you follow 'finalise programming' or settings won't be saved.
<b>11</b>	Poor remote range.	Check remote batteries. Try remote. Check the antenna cable end is not touching metal	Metal doors and foil backed plasterboard reduce range. You may need to extend the antenna.

## Accessories

We recommend the wireless accessories which require only programming

- FA62** Wireless keypad
- FR11** Wireless button

Openers have a 12Vdc supply suitable to power access controls and sensor devices of your choice.

- FA30** Photobeam
- FA61** Keyswitch
- VY805** Wired button

Wired connections are made to screw terminals on the main PCB. They have been colour coded for simplicity. All 5 wires connect to one corner of the PCB. See below for wiring.

- GREEN** Button input
- VIOLET** +5Vdc (button com)
- BLUE** Ground (photobeam com)
- YELLOW** Photobeam input
- RED** +12/15Vdc

Refer to the wiring notes supplied with each accessory for more information.

- Button input **GREEN & VIOLET**
- Keypad power **BLUE (-) & RED (+)**
- Keypad contact **GREEN & VIOLET**
- Safety edge **BLUE & YELLOW**

## Photo beam fitting

The FA30 optional photo beam prevents the door closing if the beam is blocked by a car or any other object. If an object moves into the beam while the door is closing, it will stop and re-open. Used when the automatic closing is enabled.

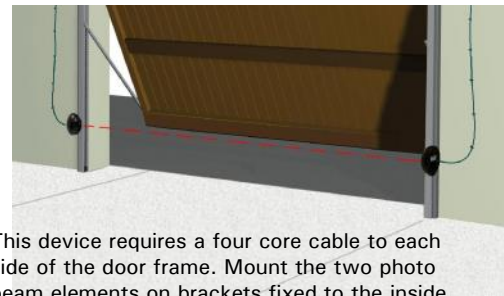

This device requires a four core cable to each side of the door frame. Mount the two photo beam elements on brackets fixed to the inside door frame 250mm above floor level. No door parts must cross the beam in normal travel. Keep the cable clear of moving door gear. Any damage will stop the door closing.

The photobeam function must now be enabled in the programming. See step 4.

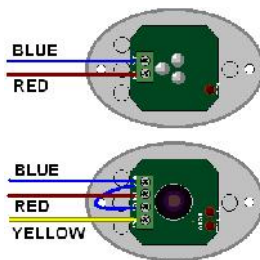

## PCB

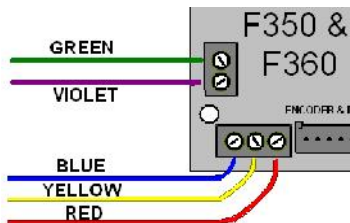

There is a single PCB with a number of connectors for dedicated functions. Two screw terminals in the corner are for the accessory connections. Switch the power off before taking the housing off.

There are two 2.5A fuses, one for the lamp, one for the transformer. Bulb type is a 230Vac 25W E14 accessible through the white cover.



## Manual operation

A disconnect pull cord is fitted to the rail to allow the door to open in the unlikely event of a power failure. Pull once, then lift the door manually. The door will re-engage the drive automatically on the next cycle.



A door mounted release is available for releasing the door from outside.

## Maintenance & repair

An opener fitted and maintained to these instructions will give long reliable service. The door's running gear must be kept in good working order. We recommend the door is operated manually at least once per month to check for wear. Openers will hide problems developing within the door tracks and springs. Faults not attended to early may develop.

Opener damage resulting from poor maintenance is not covered by the warranty. Spares are available from your dealer. For safety, only competent persons should be allowed to fit spare parts.

Programming steps 1,2,3 and 6 should be repeated if the motor or drive train parts are replaced. All programming will need to be repeated if the PCB is replaced.

## Safe operation

Garage doors and openers can be dangerous. These safety warnings are to protect users of automated doors. Cut this label out and stick it to the door, or download a new copy.

### WARNING – AUTOMATIC DOOR

- Do not let children operate or play with remotes.
- Never go under the door when partially open.
- Operate the door only when in eye contact.
- Keep the door regularly maintained.
- Make sure there are no people or objects in the path of the moving door.

Only authorised and responsible persons should be allowed to use the door controls.



### Declaration of Conformity

We hereby declare, that Remote Controlled Garage Door Openers F-350M, F-350G 240V have been manufactured in accordance with the following standards or normative documents ;

EN 60335-2-95: 2004  
 EN 60335-1/A13: 2008/A2: 2006  
 EN 62233: 2008  
 EN 61000-3-2: 2006, + A1: 2009 +A2: 2009  
 EN 61000-3-3: 2008  
 EN 55014-1: 2006 +A1: 2009 EN 55014-2: 1997 +A2: 2008  
 EN 50371: 2002

In accordance with the provisions of the following directives  
 98/37/EC Machinery Directive with amending directives  
 2006/95/EC LV Directive  
 2004/108/EEC EMC Directive  
 1999/5/EC R&TTE Directive

23.03.2011 – FOREMATIC  
 9 Vanalloys Estate, Stoke Row,  
 Henley RG9 5GW, United Kingdom

  
 Mr H WYNN JONES  
 Director

## Warranty

**Period**

The purchaser is granted a warranty covering the safe and reliable function of the Foresee Garage Door Operator (Mechanics, Motor and Motor Control Systems) for a period of 3 years from the date of purchase. The warranty period for replacement parts is 6 months or to the end of the current warranty period, whichever is longer.

**Requirements**

Warranty claims are only applicable in the country where the Operator was purchased. The product must have been purchased through our authorised distribution channels. The warranty only covers damage to the contract object. The fully completed warranty card together with the receipt of purchase correspondingly dated substantiates your right to claim under the warranty.

**Performance**

During the warranty period we undertake to rectify any and all defects to the Foresee product which can be proved to be attributed to a material or manufacturing fault. We will, at our discretion, either exchange a defective product for a fault free product, repair it or make a refund. We do not accept costs for dismantling and installation, or for carriage. Parts replaced under warranty are the property of the warrantor.

**Warranty exceptions**

The warranty does not cover damage caused through:

- Wear & Tear
- Improper Installation
- Negligent Care and/or Maintenance
- Improper Initial and/or Subsequent Use
- Negligent or Wanton Destruction
- External substances such as water, salt, alkaline or acid solution
- Abnormal Environmental Influences
- Mechanical damage through improper Transport and/or Installation
- Additional Priming or other Surface Protection treatments
- Repair by Non-qualified or Incompetent Persons
- Using non-Foresee parts without the Approval of the Manufacturer
- Removal of product Identification, or otherwise making it unidentifiable

A separate 2 Year warranty is granted on Radio Equipment, accessories and system controls. There is no warranty on Consumables (eg fuses, batteries, bulbs)

**Forematic**

9 Vanalloys Estate  
Stoke Row  
Henley RG9 5QW